



Temporary Park Camp Requirements Fact Sheet

As defined in Ohio Revised Code 3729.01 (V), a “temporary park camp” is any tract of land used for a period not to exceed a total of twenty-one days per calendar year for the purpose of parking five or more recreational vehicles, dependent recreational vehicles, or portable camping units, or any combination thereof, for one or more periods of time that do not exceed seven consecutive days.

Plan Review

A set of plans must be submitted to Geauga Public Health at least fifteen (15) days prior to the event, and must contain the following in order to gain approval:

- One set of drawings, which depict all items as described in the plan review application (form HEA 5336), see item number 4 on the back of the plan review application for the list of items.
- Per OAC 3701-25-05(c)(3) written verification from the local Fire Department that the camp can be provided with proper and sufficient fire protection. Note: Documentation may be in the form of an email directly from the Fire Department, or hard copy letter on the Fire Department’s letterhead.

Licensure

Once the plans are approved, the camp will be approved for licensure. In order to be licensed, a license application (Form HEA 5336) must be completed and submitted with the \$100.00 application fee.

Note: Temporary park camp plan review and licensing applications may be found at www.gphohio.org.

Operational Requirements

- Compliance to all regulations described in this document.
- All park/camp buildings, sites, and facilities shall be maintained in a safe and sanitary manner at all times.
- The park/camp shall be properly drained to eliminate standing water, and free from all trash and debris.
- Pests and other nuisances shall be prevented and abated immediately if they occur.
- All roads and walkways shall be maintained.

Spacing

The minimum spacing requirements for recreation vehicles are highlighted below.

Recreational Vehicles	Minimum Spacing
Side to Side	15 Feet
End to Side	10 Feet
End to End	10 Feet
From any Building	15 Feet
From any Public Road	15 Feet
From Park/Camp Roads	10 Feet
From Property Lines	7.5 Feet

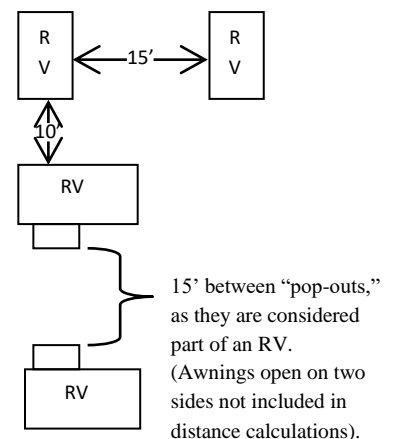

Water

It is not required that water be provided at the camping sites. However, if water is provided, it must meet Ohio EPA requirements.

If water is provided, the hoses connecting the units to the water supply must be approved hoses for drinking water (food grade).

In order to prevent contamination of the water supply, approved backflow prevention must be utilized at the main water source. ASSE-1013 backflow prevention assemblies and ASSE-1024 dual check valve backflow prevention devices at individual connection points (or their equivalents) are acceptable.

Sewage/Wastewater

Adequate sewage/wastewater disposal must be provided by using a combination of the following:

- A designated dump station
- Individual watertight containers at each site
- The services of a registered sewage hauler to pump out RV tanks

NOTE: It is critical that sewage/wastewater not be disposed of on the grounds or into storm sewers, as this could directly contaminate natural waterways.

Toilets

Toilets must be provided as indicated in the chart below:

Sites #	Men		Women
	Urinals	Toilets	Toilets
5-15		1	1
16-30	1	1	2
31-60	1	2	3
61-90	2	2	4
91-120	2	3	5
121-150	3	3	6
151-200	4	4	8
201-300	5	5	10
301-400	6	6	12
401-500	7	7	14
501+ Add 1 per 200 for men and 2 per 200 for women			

Toilets must be located within 1,000 feet walking distance from camp sites.

Trash

Trash containers must be provided for proper disposal of trash and waste. Sufficient capacity and pickup must be met so dumpsters do not overflow. Dumpster lids must remain closed when not in use. **Note:** In order to prevent the attraction of pests, it is critical that all trash be properly contained/not left on the grounds.

Safety

Fire-fighting equipment of the type and quantity acceptable to the State of Ohio Fire Marshal or local Fire Department shall be made available for use in firefighting. All firefighting equipment shall be maintained in good operating condition (not expired), and located so it is easily accessible at all times.

If Geauga Public Health believes an electrical hazard exists, the operator will be required to provide written documentation indicating that all electrical systems at the park/camp meet applicable state and local electrical codes.

First aid equipment consisting of disposable gloves, a sufficient supply of materials to stop bleeding, and to clean and cover minor cuts and abrasions shall be maintained and easily accessible.

The operator shall maintain a record of all injuries occurring within the park requiring the attention of medical personnel licensed under Chapters 4723, 4730, and 4731 of the Ohio Revised Code.

The operator shall ensure that no motorized vehicles are operated in such a manner as to create hazards to life and safety.

The operator shall identify all natural hazards within the park/camp and eliminate them whenever possible.

Firearms and other potentially hazardous equipment and substances shall be used, stored, and maintained in a safe manner.

The operator shall control any potentially hazardous activities or excessive noise within the park/camp.

Animals/Pets

The operator shall promptly report all cases of domestic and wild animal bites within the park/camp to the local animal control official and Geauga Public Health at 440-279-1914.

If you have any questions regarding the Temporary Park Camp Program, please contact:

Geauga Public Health

Environmental Health Division

440-279-1914

Temporary Campground Application for Plan Review and License to Operate

Name of Temporary Campground			Health District		
Address of event			<p style="text-align: center;">Directions: (please print)</p> <ol style="list-style-type: none"> 1. Complete <u>one application</u> for each temporary campground event; 2. Sign and Date the application; 3. Include the required items for review per OAC 3701-26-05(C)(10) 4. License will not be issued until plan review is approved. 5. Contact Local Health District to obtain the license fee amount. 		
City/Zip					
Start date	End date	# of days for this event (≤7 days)			
Name of Owner / Licensee					
Address					
City/ State /Zip					
Phone #		E-mail			
Number of sites proposed		Water Supply Public PWS Private N/A		Type of Sewerage System Municipal Dump Station(s) Septage Hauler	
Fires permitted on campsites? Yes No		PWS name:		On-site N/A Other:	
			Local Fire District		

Person to Contact regarding inspections, maintenance, or emergencies, if different from licensee.

Name	Phone #	E-mail
------	---------	--------

I hereby certify that I am the licensee, or the authorized representative of the establishment listed above, and agree to abide by the rules that apply for this license. I certify that the information provided is a true and accurate statement of the facts.

Signature	Date
-----------	------

Check or money order for the license fee, payable to:

Return the fee and application to:

<p><i>(Licensor to complete: either pre-printed, or with a label or stamp)</i></p>	Health District	
	Street address	
	City	
	Zip	Phone #

LOCAL LICENSING AUTHORITY TO COMPLETE BELOW

Date Plan Review Application Rec'd:	Date Plan Review Approved:	Number of Days Licensed this Year (including this event):
Plan Review Approved by:	Number of sites approved:	License Fee: \$

Application approved for license as according to the applicable sections of the Ohio Revised Code

Processor:	Date payment received:	Date Processed:
License Audit No.	Health District License No.	